



The TEX-CTR10 indicator is the ideal solution for a variety of counting and rate application requirements.

This meter has been designed for ease of use, with intuitive, scrolling text prompts that guide you step-by-step through the setup process.

The front panel includes a 6 digit LED display and five front panel buttons, for simple operator interface.

One of the five buttons is user-programmable, so you can customise it as a shortcut to your most frequently used feature.

Order Codes

TEX-CTR10

- HV 85-265V AC / 95-370V DC
- LV 15-48V AC / 10-72V DC

Options

- A 1 x mA/V analog output
- S2R 1 x RS232 (RJ11 terminal)
- S4S 1 x RS485 (screw terminal)

Contents

1 - Specifications	2
2 - Casing & Display	3
3 - Wiring	5
4 - Input Setup & Calibration	9
5 - Reset PIN Number	15
Appendix A - Input Header Configuration	16
Appendix B - Serial Modes	17

1

SPECIFICATIONS

Sensor type NPN (open collector, default configuration) PNP, tacho, TTL, digital, closed contact or namur also available	<i>DEFAULT</i>
Input 0-24V DC, 0-30V AC	
Power supply HV (85-265V AC/95-370V DC) or LV (15-48V AC/10-72V DC)	
Analog output 1 x isolated 16 bit analog output, 4-20mA or 0-10V. Can be wired for either current or voltage. Fully scalable. Window program- mable over any range within the controller's full-scale range.	<i>OPTIONAL</i>
Serial port Isolated RS232 (RJ11) or RS485 (screw terminal) Output mode: Custom ASCII, Modbus RTU slave or Ranger A. Data rate: 300-38400 baud. Parity: Odd, even or none.	<i>OPTIONAL</i>
Excitation 24V DC (50mA max) provided by controller	
Input frequency Counter: 100kHz max; Rate: 10kHz max, (100kHz max in high speed mode - see 4.3F to enable)	
Sampling rate Counter: 10msec; Rate: 100msec	
Pulse width Minimum pulse width must be greater than 5 μ s	
Rate resolution 0.01Hz (1Hz with high speed mode on - see 4.3F to enable)	
Rate accuracy 0.005%	
Rate temperature drift Typically 2ppm/ $^{\circ}$ C	
Input noise filtering 20kHz, 2kHz, 200Hz or off	
Security Setup PIN code protected for security	

2

CASING & DISPLAY

2.1 - Case dimensions

Dimensions 48H x 96W x 120D (mm). *When calculating space requirements, please allow 30-50mm clearance behind the unit for connectors and wiring.*

Panel cutout 45H x 92W (mm)

Display 1 x 6 digit (13mm), 14 segment alphanumeric LED

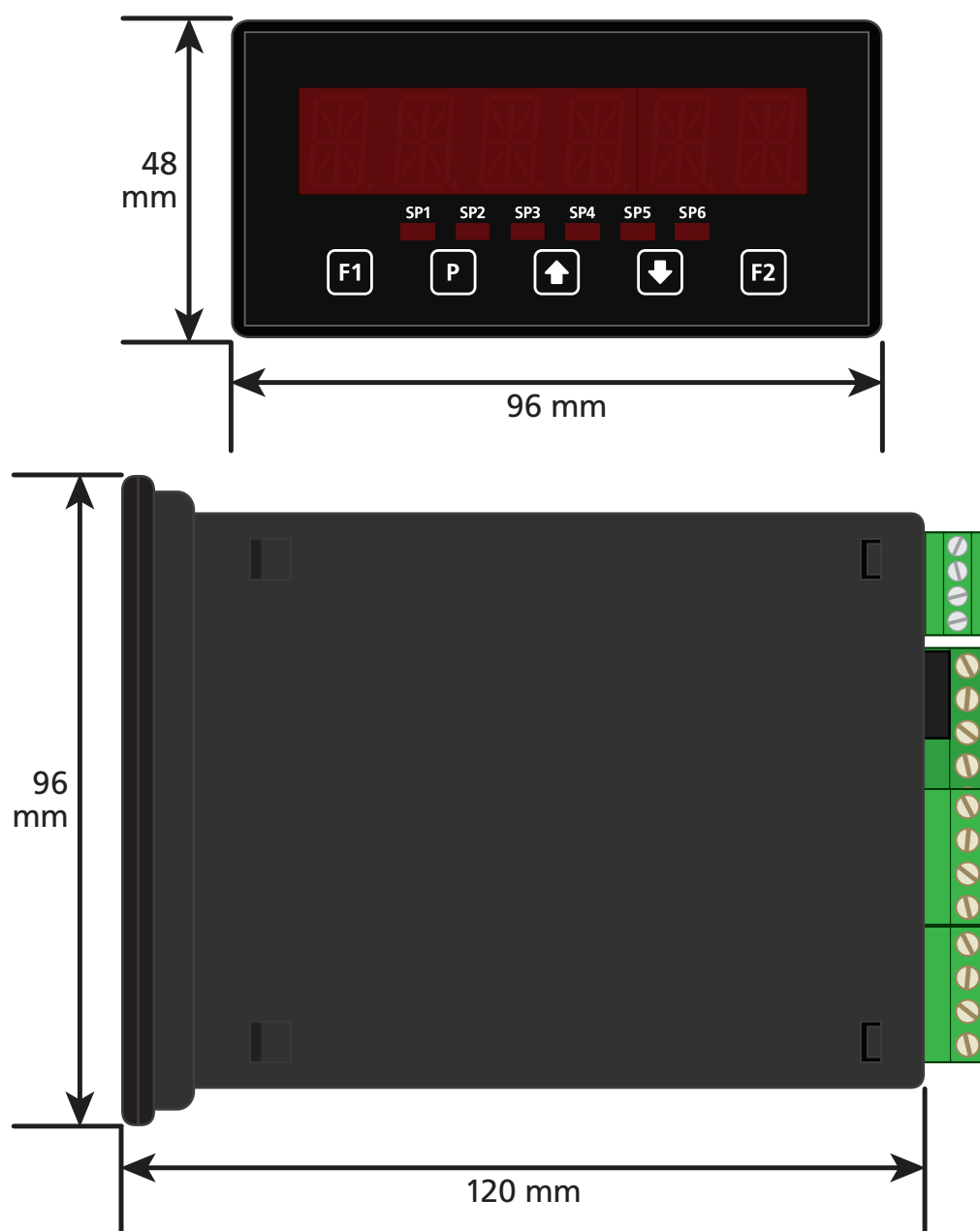

2.2 - Front panel

SPX The SP LED's are not active for this model.

- F1** This button is used to access the **Input Setup & Calibration** menu (Section 4).
 - P** This button is used to save your settings and advance to the next step in the setup process. Pressing this button from the operational display will hold the current display value (totalizer and rate values continue running in the background).
 - ↑** This button is typically used to scroll through options or increase values in the setup menu. Pressing this button from the main display will show the current rate value (see 2.3).
 - ↓** This button is typically used to scroll through options or decrease values in the setup menu. Pressing this button from the main display will show the current totalizer value (see 2.3).
 - F2** The function of a single keypress of this button from the operational display can be user programmed. By default, no function is assigned - see 4.5B to enable.
-

2.3 - Up and down button shortcuts

- ↑** Press the **↑** button from the main display. **RATE** appears and toggles with the current rate value. Press **P** to return to the main display.
 - ↓** Press the **↓** button from the main display. **TOTAL** appears and toggles with the current totalizer value. Press **P** to return to the main display.
-

2.4 - Display brightness

To adjust the display brightness, press the **P** and **↑** buttons together from the main display. **BRI** appears and toggles with the current setting. Use the **↑** and **↓** buttons to adjust the LED backlight, and then press **P** to return to the normal operating mode.

3

WIRING

BEFORE YOU BEGIN WIRING, ensure that the unit is switched off and the power supply is disconnected.

3.1 - Pinouts

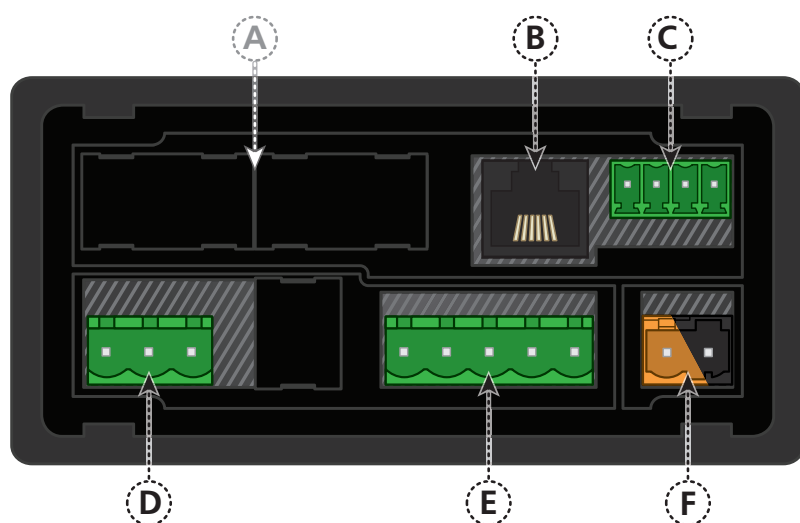

Key

A	-
B	Serial port (3.4)
C	Analog output (3.3)
D	Analog input (3.2)
E	Function pins (3.5)
F	Power supply HV/LV (3.6)

3.2 - Wire the analog input module

The input module for this unit has four headers which are factory configured to suit your application. If you do not advise us of your sensor type when you place your order, the module will be configured for an NPN sensor.

Advanced users may remove the input module from its enclosure and re-adjust the header settings. See Appendix A for more information.

Wire your input as shown in the appropriate diagram overleaf.

See 3.1D

NPN open collector output with proximity switch

- › Active sensor signal: 0V
- › Inactive sensor signal: +24V

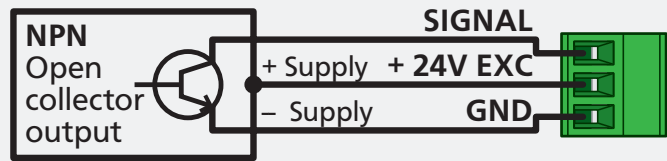

PNP open collector output with proximity switch

- › Active sensor signal: +24V
- › Inactive sensor signal: 0V

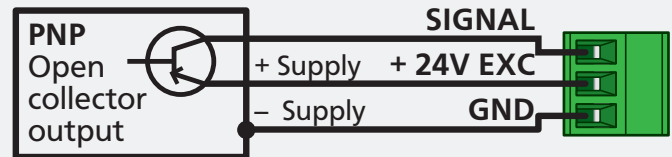

Pushbutton switch

- › Open signal: +24V
- › Closed signal: 0V

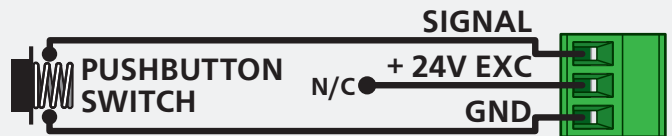

Tacho generator sensor

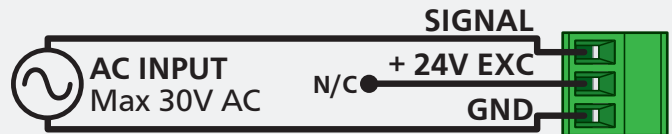

TTL input

- › In this example the TTL logic has a separate +5V power supply

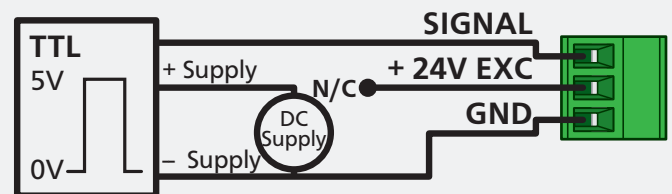

Namur sensor

- › Active sensor signal: 0.3-1.0mA
- › Inactive sensor signal: 1.7 - 3.0mA

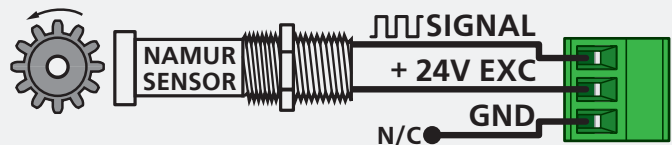

3.3 - Wire the analog output (if installed)

If your controller has analog output fitted, wire it as shown for either voltage (0-10V) or current (4-20mA).

See 3.1C

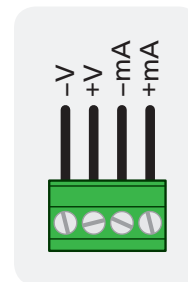

3.4 - Wire the serial port (if installed)

If your controller has serial port fitted, wire it as shown in the applicable diagram. (S2R: RS232, RJ11 terminal, S4S: RS485, screw terminal).

See 3.1B

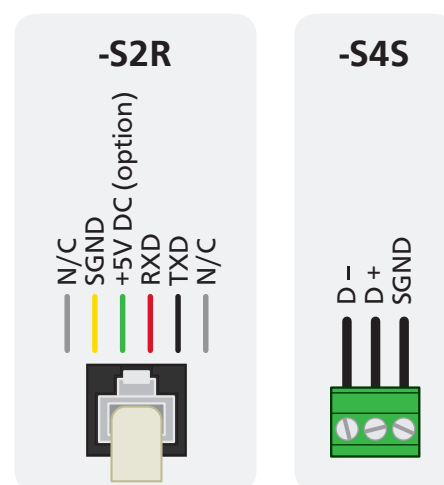

3.5 - Wire the function pins

Connect external switches to enable a function to be executed when its switch is activated.

- › **User 1:** User defined function (see 4.5C)
- › **Inhibit:** Prevents the totalizer from counting
- › **Test:** Resets the unit
- › **User 2:** User defined function (see 4.5D)

See 3.1E

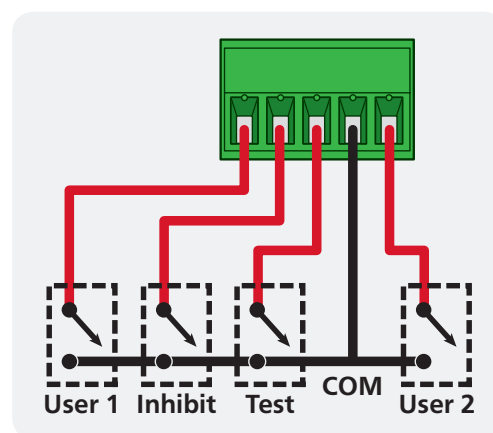

3.6 - Wire the power supply

DO NOT attempt to wire your controller while the power is on. NEVER connect your low voltage controller to mains power.

Wire your controller for low or high voltage power supply, as show in the diagrams below. Check the label on the unit against the colour of the connector:

- › **Orange =**
High voltage (85-265V AC,
95-370V DC)
- › **Black =**
Low voltage (15-48V AC,
10-72V DC)

See 3.1F

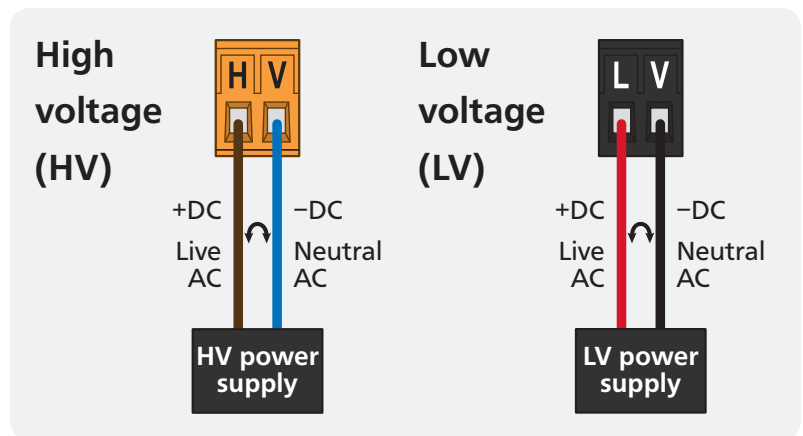

Once you have completed the wiring process it is safe to switch on your power supply. Ensure that your display is functioning before you proceed.

4

INPUT SETUP & CALIBRATION

4.1 - Enter F1 PIN number

A Enter the setup and calibration mode by pressing the **F1** button.

___ ENTER F1 PIN NUMBER scrolls across the display and toggles with **0**. Use the **↑** and **↓** buttons to enter your security code (factory default 1). Then press **P**. If the correct PIN is entered, setup is started at 4.2.

If an incorrect PIN number is entered, **___ INCORRECT PIN NUMBER – ACCESS DENIED** scrolls across the display and it returns to normal operating mode.

You will have the opportunity to change your PIN number at the end of this section (4.8). If you have forgotten your PIN number, see Section 5.

4.2 - Totalizer setup

A **___ TOTALIZER SETUP** scrolls across the display and toggles with **SKIP**. Press **P** to skip to 4.3, or the **↑** button and then **P** to **ENTER** totalizer setup.









B **___ DECIMAL POINT POSITION** scrolls across the display and toggles with the currently selected decimal point position. Use the **↑** and **↓** buttons to select **NO DP, 0.1, 0.12, 0.123, 0.1234** or **0.12345**, and then press **P**.

C **___ PULSES PER UNIT OF MEASUREMENT** scrolls across the display and toggles with the currently selected number of pulses. Use the **↑** and **↓** buttons to adjust your number of pulses, and then press **P**.

E.g. If an encoder outputs 1,500 pulses/metre, set this value to 1,500.









D **___ ENTER DISPLAY VALUE FOR X PULSES** (where X is the number of pulses selected in 4.2C) scrolls across the display and toggles with the selected display value. Adjust this value as required using the **↑** and **↓** buttons, and press **P**.

E.g. If you set 1,500 pulses in 4.2C, and 1,500 pulses = 1 metre, then enter 1 here.



- E** ___ **DIRECTION** scrolls across the display and toggles with the currently selected count direction. Use the  and  buttons to select either **UP** or **DOWN**, and then press .
- F** ___ **RESET AT POWER UP** scrolls across the display and toggles with the current setting. Use the  and  buttons to choose between: **NO** (retain previous totalizer value at power up), **ZERO** (reset totalizer to zero at power up) or **LD VAL** (reset totalizer to custom load value (see 4.2G) at power up). When you have made a selection, press .
- G** ___ **LOAD VALUE** scrolls across the display and toggles with the current totalizer load value. Use the  and  buttons to adjust this value if required, and then press .

*This value will be loaded into the totalizer at power up, if **LD VAL** is selected in 4.2F above. It will also be loaded into the totalizer if **TOT=LV** is executed via a user programmable input function (see 4.5).*















4.3 - Rate setup

- A** ___ **RATE SETUP** scrolls across the display and toggles with **SKIP**. Press  to skip to 4.4, or the  button and then  to **ENTER** rate setup.
- B** ___ **DECIMAL POINT POSITION** scrolls across the display and toggles with the currently selected decimal point position. Use the  and  buttons to select **NO DP**, **0.1**, **0.12**, **0.123**, **0.1234** or **0.12345**, and then press .
- C** ___ **ROUNDING** scrolls across and toggles with the current display rounding setting. Using the  and  buttons, select: **NONE**, **2**, **5** or **10**, and press .

*Rounding is quoted in display counts and is not influenced by decimal point position. For example, if your input signal is 5.3, the display will show: 5.3 (for rounding=**NONE**), 5.4 (for rounding=**2**), 5.5 (for rounding=**5**) or 5.0 (for rounding=**10**).*

- D** ___ **TIME PERIOD FOR RATE DISPLAY** scrolls across the display and toggles with the currently selected time period. Use the  and  buttons to select: **SECS**, **MINS** or **HOURS**, and then press .

This parameter allows you to view the effective rate over different time periods. For example, if the units of measurement are metres, then the rate can be viewed in metres/second, metres/minute or metres/hour. The instrument will automatically calculate the required scale factors based on the input channel setup, so you must complete 4.2 first.



- E** ___ **RATE MULTIPLIER** scrolls across the display and toggles with the current multiplication factor. This option adds a scale factor, to display the rate in the required units. Use the  and  buttons to select: **X0.0001**, **X0.001**, **X0.01**, **X0.1**, **X1**, **X10**, **X100** or **X1000**. Then press .
- F** ___ **HIGH SPEED MODE** scrolls across the display and toggles with the current selection. High speed mode should be turned on when the input signal is greater than 10,000pps (10kHz). Use the  and  buttons to select either **ON** or **OFF**, and then press .
- G** ___ **LOW CUT** scrolls across the display and toggles with the cutoff value for the rate display. When the rate drops below the low cut value, it displays as zero. Use the  and  buttons to adjust this value as required, and then press .
- H** ___ **DISPLAY ZERO TIME** scrolls across the display and toggles with the current display zero time. This value controls how quickly the rate display changes to zero. Use the  and  buttons to select either: **0.5SEC** (for inputs with >2 pulses/sec) or **100SEC** (for slow inputs). Then press .
- I** ___ **AVE SAMPLES** scrolls across the display and toggles with the currently selected averaging. Using the  and  buttons, alter the number of input samples that the controller will average, and then press .

This instrument has input signal averaging, optimising stable measurement.

If the change in input exceeds the averaging window value it will not average, ensuring fast response when there are large differences between readings.

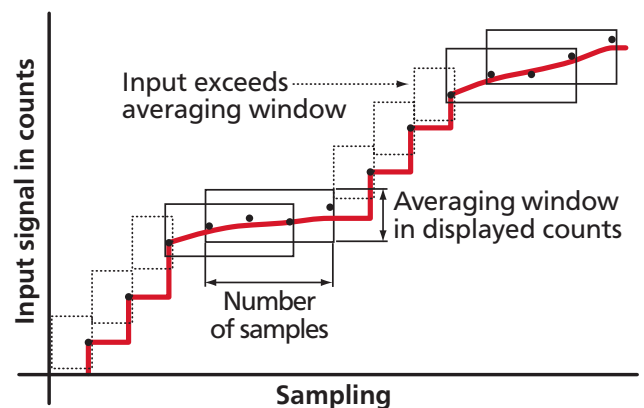
*Increasing the number of **AVE SAMPLES** will stabilise measurement, but it will also slow down response rates.*



- J** ___ **AVE WINDOW** scrolls across and toggles with the currently selected averaging window value. Using the  and  buttons, alter the signal averaging window, and then press .

*If your input signal contains large noise spikes, you can increase the size of the averaging window to ensure that these are still averaged. However, increasing the window size too far will reduce the ability of the instrument to respond quickly to real changes in input signal. Setting **AVE WINDOW** to 0 will give continuous averaging as per the selected averaging samples.*

4.4 - Display setup

- A** ___ **DISPLAY SETUP** scrolls across the display and toggles with **SKIP**. Press **P** to skip to 4.5, or the **↑** button and then **P** to **ENTER** display setup.
- B** ___ **DISPLAY SOURCE** scrolls across the display and toggles with the currently selected display source. Use the **↑** and **↓** buttons to select either **TOTAL** or **RATE**, and then press **P**.

4.5 - User programmable input functions

This section allows you to assign a custom function to the front panel **F2** button, or the rear *User* input pins (see 3.5). The following functions are available:

User programmable input functions

NONE	No action
STORE	Freezes the display value (totalizer and rate keep operating in the background)
TOT=0	Resets total value to zero
TOT=LV	Resets total value to load value (defined in 4.2G)

- A** ___ **USER PROGRAMMABLE INPUT FUNCTIONS** scrolls across the display and toggles with **SKIP**. Press **P** to skip to 4.6, or the **↑** button and then **P** to **ENTER** input functions setup.
- B** ___ **F2 BUTTON** scrolls across the display and toggles with the function to be executed when the **F2** button is pressed from the main display. Use the **↑** and **↓** buttons to make a selection (referring to the table above). Then press **P**.
- C** ___ **USER INPUT 1** scrolls across the display and toggles with the function to be executed when the User 1 input pin is activated (see 3.5). Use the **↑** and **↓** buttons to make a selection (referring to the table above), and then press **P**.
- D** ___ **USER INPUT 2** scrolls across the display and toggles with the function to be executed when the User 2 input pin is activated (see 3.5). Use the **↑** and **↓** buttons to make a selection (referring to the table above), and then press **P**.

4.6 - Analog output setup

A **___ ANALOG OUTPUT SETUP** scrolls across the display and toggles with **SKIP**. If your unit does not have analog output installed, (or you do not wish to configure your analog output now), please press **P** to skip to 4.7.

Otherwise, press the **↑** button and then **P** to **ENTER** analog output setup.

B **___ DATA SOURCE FOR ANALOG OUTPUT** scrolls across the display and toggles with the current analog output data source. Use the **↑** and **↓** buttons to select an option from: **NONE**, **TOTAL** or **RATE**, and then press **P**.

C **___ LOW SCALE VALUE FOR ANALOG OUTPUT** scrolls across the display and toggles with the currently selected low scale value. Use the **↑** and **↓** buttons to enter your cal low position, and then press **P**.

*This sets the display value for **CAL LOW** (as in 4.6F, below).*

D **___ HIGH SCALE VALUE FOR ANALOG OUTPUT** scrolls across the display and toggles with the currently selected high scale value. Use the **↑** and **↓** buttons to enter your cal high position, and then press **P**.

*This sets the display value for **CAL HIGH** (as in 4.6G, below).*

E **___ CALIBRATE ANALOG OUTPUT?** scrolls across the display and toggles with **SKIP**. If you do not wish to calibrate your analog output then press **P** now to skip to 4.7.

To calibrate your analog output now, connect a mA or volt meter across the analog output connector (see 3.3). Then press the **↑** button, followed by **P**, to **ENTER** analog output calibration mode.

F **___ CAL LOW ANALOG OUTPUT** scrolls across the display and toggles with a calibration number displayed in internal units (mA or V). Using the **↑** and **↓** buttons, calibrate your low analog output as required, and then press **P**.

G **___ CAL HIGH ANALOG OUTPUT** scrolls across the display and toggles with a calibration number displayed in internal units (mA or V). Using the **↑** and **↓** buttons, calibrate your high analog output as required, and then press **P**.

4.7 - Serial setup

A ___ **SERIAL SETUP** scrolls across the display and toggles with **SKIP**. If your unit does not have a serial port installed, (or you do not wish to configure your serial options now), please press **P** to skip to 4.8.

Otherwise, press the **↑** button and then **P** to **ENTER** serial setup.

B ___ **SERIAL MODE** scrolls across the display and toggles with the currently selected serial mode. Using the **↑** and **↓** buttons, choose either: **ASCII** (custom), **MODBUS** (RTU) or **RNGR A** (Ranger A), and then press **P**.

➔ If you selected **ASCII** or **MODBUS**, skip to 4.7D now.

➔ If you selected **RNGR A**, continue to 4.7C now.

C ___ **SERIAL DATA SOURCE** scrolls across the display and toggles with the current Ranger A serial data source. Use the **↑** and **↓** buttons to select either **RATE** or **TOTAL**, and then press **P**.

D ___ **BAUD RATE** scrolls across the display and toggles with the current selection. Use the **↑** and **↓** buttons to select one of: **300**, **600**, **1200**, **2400**, **4800**, **9600**, **19200** or **38400**. Then press **P**.

E ___ **PARITY** scrolls across the display and toggles with the current selection. Using the **↑** and **↓** buttons, select: **NONE**, **ODD** or **EVEN**, and then press **P**.

F ___ **SERIAL ADDRESS** scrolls across the display and toggles with the current address. Use the **↑** and **↓** buttons to alter the serial address, and press **P**.

*The serial address parameter is used to identify a particular device when it is used with other devices in a system. (It applies particularly to **MODBUS** mode when used on an RS485 serial network.) The serial address of the controller must be set to match the serial address defined in the master device.*

Refer to Appendix B for more information on serial modes and registers.

4.8 - Edit F1 PIN number

- A** **__ _ EDIT F1 PIN NUMBER** scrolls across the display and toggles with **SKIP**. Press **P** to skip and return to the operational display, or the **↑** button and then **P** to **ENTER** and change your PIN number.
- B** **__ _ ENTER NEW F1 PIN NUMBER** scrolls across the display and toggles with the current PIN (default 1). Using the **↑** and **↓** buttons, enter your new calibration PIN number. Then press **P** to exit to the operational display.

5

RESET PIN NUMBER

If you have forgotten your F1 PIN number, follow the procedure below to reset the PIN to its factory default of 1.

- A** Press **↑**, **↓** and **P** at the same time. (This key combination can be difficult to execute and you may need several tries to get it right.)
- B** When successful, a factory identification text will scroll across the display, followed by **- PIN NUMBERS RESET TO 1**
- C** Reset the default PIN number if required by following the instructions in 4.8, entering '1' whenever you are prompted for your current PIN.

A

APPENDIX A - INPUT HEADER CONFIGURATION

We recommend that you specify your sensor type when you place your order, to avoid unnecessary removal of the input module. If you do not advise us of your sensor type when you place your order, the module will be configured for NPN.

A.1 - To configure the input headers:

- A** Disconnect the power and unplug all connected terminals from the controller
- B** Open the case by inserting a screwdriver into the indentations on the black case, and levering the back plate off
- C** Remove the input module from the case and make adjustments as needed, referring to the header tables below:

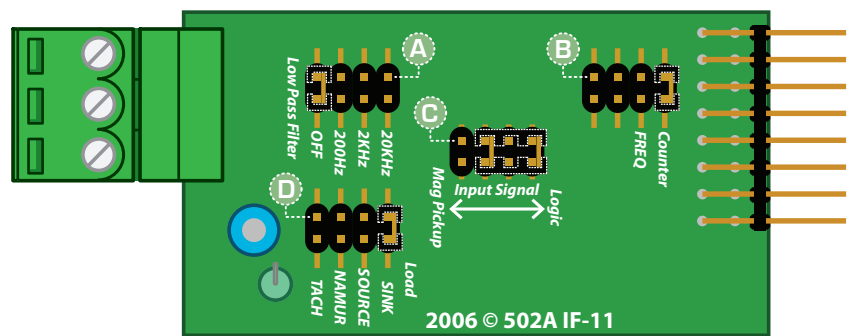

Low Pass Filter (A)

OFF	Ideal for high-speed counting
200Hz	Ideal for mechanical contacts
2KHz	Suitable for a noisy signal
20KHz	Suitable for a noisy signal

Input Signal (C)

Logic	NPN, PNP, namur, TTL & pushbuttons
Mag Pickup	Tacho

Mode (B)

Counter	Always use this setting
FREQ	Not used for TEX-CTR10

Load (D)

SINK	NPN, TTL & pushbuttons
SOURCE	PNP
NAMUR	Namur
TACH	Tacho

B**APPENDIX B - SERIAL MODES**

B.1 - Custom ASCII mode

Custom ASCII is a simple, custom protocol that allows connection to various PC configuration tools. ('Custom ASCII' differs from the 'Modbus (ASCII)' protocol used by some devices.) Custom ASCII command strings must be constructed in this order:

**<Start> <Controller Address> <Read/Write Command> <Register Address>
<Separator Character> <Data Value> <Message Terminator>**

Start - Use 'S' for the start character of a command string (not case sensitive). This must be the first character in the string.

Controller Address - Use an ASCII number from '1' to '255' for the controller address. If the character following the start character is not an ASCII number, then address '0' is assumed. All controllers respond to address '0'.

Read/Write Command - Use ASCII 'R' for read, 'U' for unformatted read, or 'W' for write (not case sensitive). Any other character aborts the operation.

In Custom ASCII mode, data is normally read as formatted data (which includes decimals and any text characters that may be selected to show units). However it is also possible to read unformatted data by using a 'U' in the read command. There is no unformatted write command, as when writing to fixed point registers, any decimal point and text characters are ignored.

Register Address - The register address for the read/write operation will be an ASCII number from '1' to '65535'. This character must be specified for a write command, but may be omitted for a read command, (in which case the controller will respond with the data value currently on the display).

Separator Character - The separator character can be either a space or a comma, and is used to separate the register address from the data value.

Data Value - Must be an ASCII number. The absolute limits for this number are -1000000 to 1000000, but please note that not all registers will accept this range.

Message Terminator - This is the last character, and must be either a '\$' (dollar) or an '*' (asterisk). Neither of these characters should be used elsewhere in the

message string. If '\$' is used, a 50ms minimum delay is inserted before a reply is sent. If '*' is used, a 2ms minimum delay is inserted before a reply is sent.

Custom ASCII Read/Write Examples

Example	Description
SR\$	Read display value from all controllers, 50ms delay.
S15R\$	Read display value from controller address 15, 50ms delay.
S3U40*	Read unformatted data in channel 4 from controller address 3, 2ms delay.
S2W2 -10000\$	Write -10000 to the display register of controller address 2, 50ms delay.
SWT CHAN_1\$	Write ASCII text string Chan_1 to channel 1 text register, 50ms delay.

Custom ASCII Registers - *Active for models with relay output installed*

32 Bit Signed

Address	Function
2	Process display
4	Flow rate
5	Total
34	D/A scale low value
36	D/A scale high value

Controller Response - After the controller has completed a read or write instruction, it responds by sending a carriage return/line feed (CR/LF) back to the host. If the instruction was a read command, the CR/LF follows the last character in the ASCII string. If it was a write command, CR/LF is the only response sent back. The host must wait for this before sending further commands to the controller. If the controller encounters an error, it will respond with a null (0x00) CR/LF.

B.2 - Modbus (RTU) mode

Modbus (RTU) is an industry standard RTU slave mode that allows connection to a wide range of devices. Modbus registers are all holding registers, and should be accessed via function codes 3 and 6.

Register addresses are displayed in the Modicon™ 5-digit addressing format. I.e. Register 65=40065 (subtract 1 for direct addressing).

Modbus (RTU) Registers - *Active for models with relay output installed*

32 Bit Signed (2 x 16 Bit)

LSW	MSW	Function
40513	(40514)	Process display
40517	(40518)	Flow rate
40519	(40520)	Total
40587	(40588)	D/A scale low value
40591	(40592)	D/A scale high value

B.3 - Ranger A mode

Ranger A is a continuous output, used to drive remote displays and other instruments in the Rinstrum™ range. (Ranger is a trade name belonging to Rinstrum Pty Ltd.) Ranger A output strings are constructed as shown:

<Start> <Sign> <Output Value> <Status> <End>

Start - STX character (ASCII 02)

Sign - Output value sign (space for + and dash for -)

Output Value - Seven character ASCII string containing the current output value and decimal point. (If there is no decimal point, then the first character is a space. Leading zero blanking applies.)

Status - Single character output value status. 'U'=Under, 'O'=Over, 'E'=Error.

End - ETX character (ASCII 03)



Define Instruments Limited

 10B Vega Place, Mairangi Bay, Auckland 0632, New Zealand

 PO Box 245 West Harbour, Auckland 0661, New Zealand

Ph: +64 (9) 835-1550 | **Aus:** 1800 810-820 | **Fax:** +64 (9) 835-1250

www.defineinstruments.com