

Terminator™ ECM-Ambient-WP Electronic Control Module INSTALLATION PROCEDURES

For Ambient Sensing Thermostat Connection
(Pilot Control)



The Heat Tracing Specialists®

Terminator™ ECM-Ambient-WP INSTALLATION PROCEDURES

The following installation procedures are guidelines for the installation of the Terminator ECM-Ambient-WP Kit. For translations other than English and local language translation provided here, please contact Thermon. The English language installation procedure shall govern.

Kit Contents . . .



Item	Quantity	Description
1	1	Expediter Assembly Support Cap with O-Ring Threaded Grommet Compressor Grommet Support Base with O-Ring
2	1	Junction Box Lid
3	1	Junction Box Base with O-Ring and M25 Dust Cap
4	1	Expediter Nut
5	1	Banding
6	1	Electronic Control Module w/ Terminal Blocks <small>(Refer to terminal specifications for maximum allowable wire size)</small> ECM Type* C - Controller L - Limiter CL - Controller/Limiter <small>* The maximum pipe exposure temperature is limited to 250°C</small>
7	1	Junction Box Lid Cord
8	2	Blind Plug
9	1	Bracket
10	3	Screws
11	3	Washers
12	1	RTD Gland
13	1	RTD

Tools Required . . .

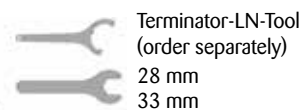

Receiving, Storing and Handling . . .

1. Inspect materials for damage incurred during shipping.
2. Report damages to the carrier for settlement.
3. Identify parts against the packing list to ensure the proper type and quantity has been received.
4. Store in a dry location.

Manuals . . .

- For operating and monitoring please refer to ECM user manual and ECM DCS guide.

Dimensions . . .

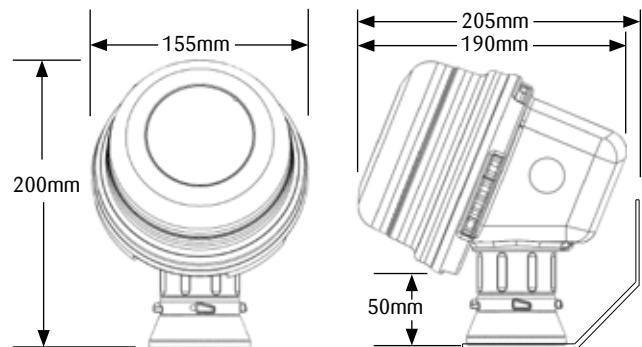

Warnings . . .

- Due to the risk of electrical shock, arcing and fire caused by product damage or improper usage, installation or maintenance, a ground-fault protection device is required.
- Installation must comply with Thermon requirements (including form PN 50273U for Ex systems) and be installed in accordance with the regulations as per the norm EN IEC 60079-14 for hazardous areas (where applicable), or any other applicable national and local codes.
- Component approvals and performance ratings are based on the use of Thermon specified parts only.
- De-energize all power sources before opening enclosure.
- Avoid electrostatic charge. Clean only with a damp cloth.
- Keep kit components dry before and during installation.
- Individuals installing these products are responsible for complying with all applicable safety and health guidelines. Proper Personal Protective Equipment (PPE) should be utilized during installation. Contact Thermon if you have any additional questions.

Certifications/Approvals . . .



II 2 (2) G Ex eb mb [ib] IIC T4, Ex tb IIIC T135°C SIRA 12ATEX5239X
II 2 (2) D Ex tb IIIC T135°C IP66 Db



International Electrotechnical Commission
IEC Certification Scheme for Explosive Atmospheres
SIR 12.0103X

Terminator™ ECM-Ambient-WP INSTALLATION PROCEDURES

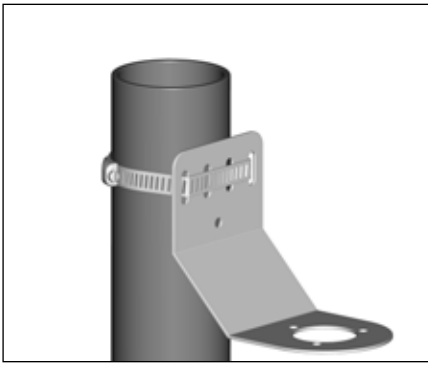

1a. Mounting Method 1: Secure wall mount bracket to mounting surface using pipe band provided with kits.

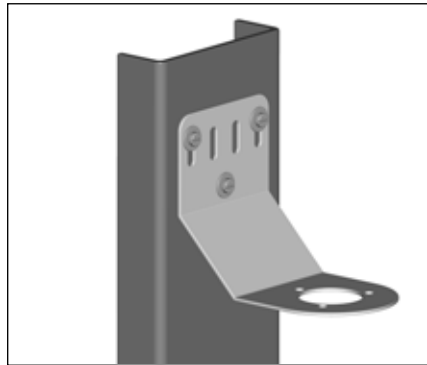

1b. Mounting Method 2: Secure wall mount bracket to mounting surface using customer supplied screws, flat washers, and nuts.

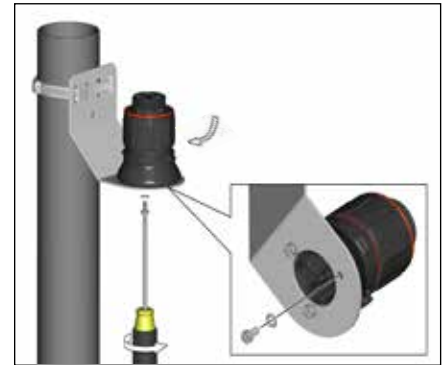

2. Mount expediter to bracket using M5 x 8mm screws and M5 lock washers. Tighten cap securely.

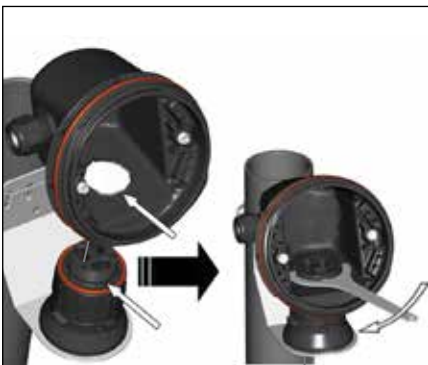

3. Mount junction box base on expediter. Make sure to align slots to properly orient junction box base. Tighten nut with Terminator-LN-Tool.



4. Remove M25 dust cap. Install M25 power gland (order separately) and M25 blind plug.

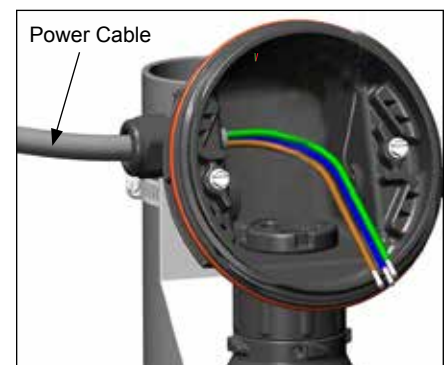

5. Install power cable and RTD. Stainless steel RTD tip must extend ≥ 20 mm out of gland.



6. Install electronic control module and complete system wiring. Terminal set screws shall be tightened to a torque value of 1,4 Nm (12,4 lb-in). See wiring details. Set module electronic control at desired setpoint.



7. Install junction box lid and twist hand tight. Insert screwdriver into ratchet slots located on side of junction box base.



8. Use screwdriver to ratchet on junction box lid. Lid will rotate 30 degrees. To remove lid, repeat steps 7 and 8 but in the opposite direction.



The Heat Tracing Specialists®

Terminator™ ECM-Ambient-WP INSTALLATION PROCEDURES

Wiring Details

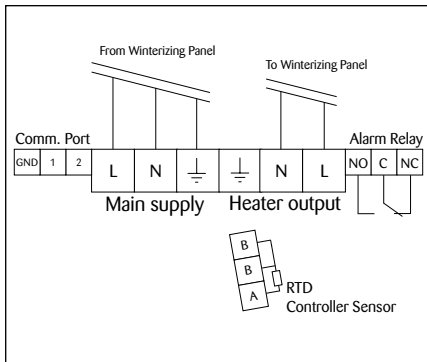

Heater output wires to winterizing panel are used to switch main winterizing contactor.



THERMON . . . The Heat Tracing Specialists®

For the Thermon office nearest you visit us at . . . www.thermon.com

European Headquarters
Boezemweg 25 • PO Box 205
2640 AE Pijnacker • The Netherlands
Phone: +31 (0) 15-36 15 370

Corporate Headquarters
100 Thermon Dr. • PO Box 609
San Marcos, TX 78667-0609 • USA
Phone: +1 512-396-5801

For Access To Installation Videos:



ISO 9001
REGISTERED

Specifications and information are subject to change without notice. Form PN50854U-0114