

Terminator™ ECM-MI-WP

Electronic Control Module

INSTALLATION PROCEDURES

For Use with MI Mineral Insulated Heating Cable Sets



The Heat Tracing Specialists®

Terminator™ ECM-MI-WP INSTALLATION PROCEDURES

The following installation procedures are suggested guidelines for the installation of the Terminator ECM-MI-WP Kit.

Receiving, Storing and Handling . . .

1. Inspect materials for damage incurred during shipping.
2. Report damages to the carrier for settlement.
3. Identify parts against the packing list to ensure the proper type and quantity has been received.
4. Store in a dry location.

Kit Contents . . .



Wire Pins (per MI cable cold lead, order separately)

Item	Quantity	Description
1	1	Expediter Assembly Support Cap with O-Ring Threaded Grommet Compressor Grommet Support Base with O-Ring
2	1	Junction Box Lid
3	1	Junction Box Base, O-Ring, M25 Dust Cap, earth plates and ground wires
4	1	Nut
5	1	Banding
6	1	Electronic Control Module w/ Terminal Blocks <small>(Refer to terminal specifications for maximum allowable wire size)</small> ECM Type C - Controller L - Limiter CL - Controller/Limiter
7	1	Junction Box Lid Cord
8	4	Blind Plug & Lock Nut
9	1	Bracket
10	3	Screws
11	3	Washers
12	2	Wire Pins

Order Separately . . .

IEK Insulation Entry Kit (per cable)

IEK-PTD For PTD lead wire



PTD100 Temperature Sensor



Dimensions . . .

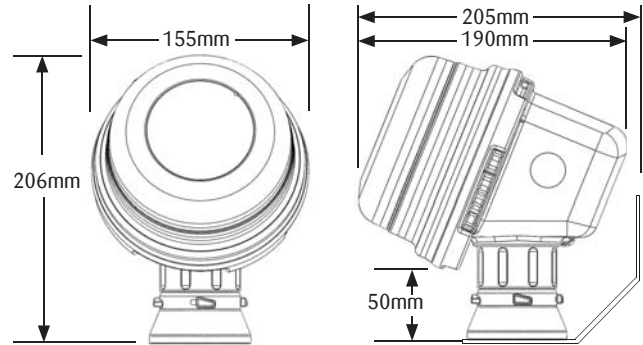

Warnings . . .

- Due to the risk of electrical shock, arcing and fire caused by product damage or improper usage, installation or maintenance, a ground-fault protection device is required.
- Installation must comply with Thermon requirements (including form PN 50273U for Ex systems) and be installed in accordance with the regulations as per the norm EN IEC 60079-14 for hazardous areas (where applicable), or any other applicable national and local codes.
- Component approvals and performance ratings are based on the use of Thermon specified parts only.
- De-energize all power sources before opening enclosure.
- Avoid electrostatic charge. Clean only with a damp cloth.
- Keep ends of heating cable and kit components dry before and during installation.
- Minimum bending radius of heating cable is six (6) times the cable outer diameter.
- Individuals installing these products are responsible for complying with all applicable safety and health guidelines. Proper Personal Protective Equipment (PPE) should be utilized during installation. Contact Thermon if you have any additional questions.

Tools Required . . .



Certifications/Approvals . . .

IP66 -60°C ≤ Ta ≤ +50°C T5, 100°C; -60°C ≤ Ta ≤ +40°C T6, 85°C
Ordinary & Hazardous Locations

FMG 10.0022X Ex db eb IIC T5-T6, Ex tb IIIC T100°C-T85°C

International Electrotechnical Commission
IEC Certification Scheme for Explosive Atmospheres
SIR 12.0103X

II 2 (2) G Ex eb mb [ib] IIC T4, Ex tb IIIC T135°C SIRA 12ATEX5239X
II 2 (2) D Ex tb IIIC T135°C IP66 Db

Terminator™ ECM-MI-WP INSTALLATION PROCEDURES

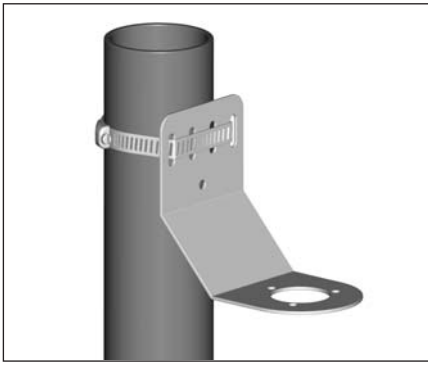

1 a. Mounting Method 1: Secure wall mount bracket to mounting surface using pipe band.

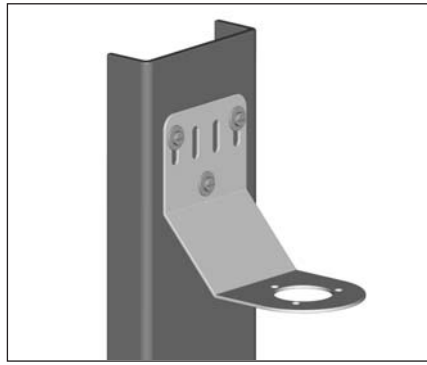

1 b. Mounting Method 2: Secure wall mount bracket to mounting surface using screws, washers, and nuts (customer provided)

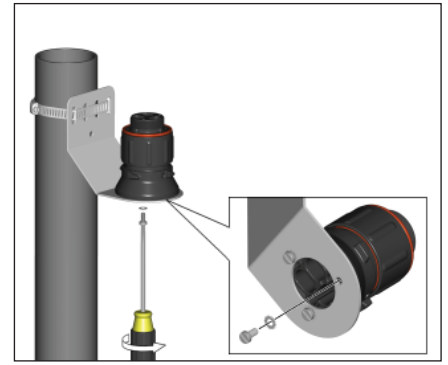

2. Mount expediter to bracket using M5 screws and lock washers.

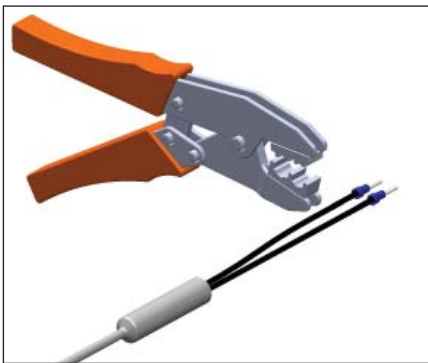

3. Crimp appropriate wire pins (2.5 mm² or 6 mm²) on MI cable cold lead wires.

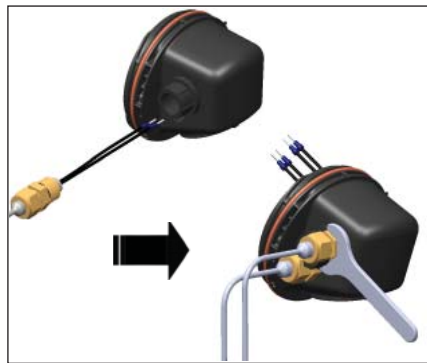

4. Route MI cable and PTD100 cold leads through M20 threaded entries. Screw cable glands into junction box.



Do not overtighten to ensure o-ring is not damaged during installation.

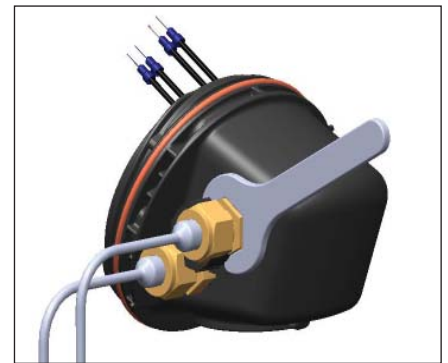

5. Center cold lead sleeve inside cable gland. Tighten cable glands until ferrule begins to make contact with cold lead sleeve and cold lead sleeve cannot be moved by hand. Tighten cable gland 1/8 additional turn or to a torque value of 16 Nm (142 lb-in).



6. Install M20 blind plug in remaining M20 threaded entry (if necessary). Additional M20 blind plug (order M20-B-EXE) will be required if only installing one gland. Tighten existing blind plugs.



7. Remove M25 dust cap. Install M25 power gland (customer supplied) in M25 threaded entry.

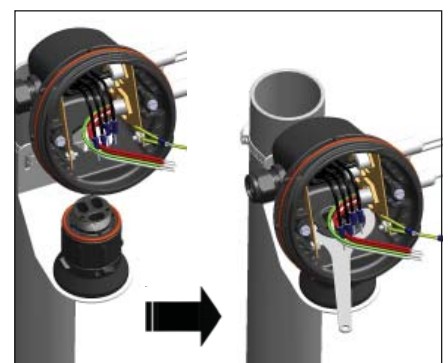

8. Mount junction box base on expediter. Make sure to align slots to properly orient junction box base. Tighten nut with Terminator-LN-Tool. If mounting horizontally, threaded gland holes must face downward.



Terminator™ ECM-MI-WP INSTALLATION PROCEDURES

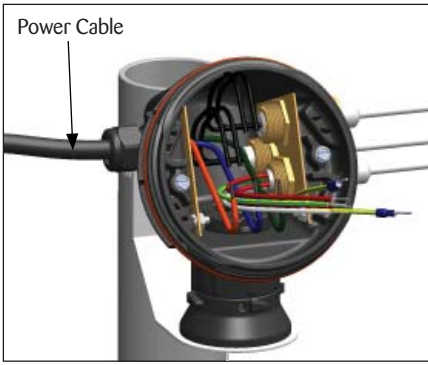

9. Install power cable (if necessary).



10. Install electronic control module and complete system wiring. Terminal set screws shall be tightened to a torque value of 1,4 Nm (12,4 lb-in). See wiring details. Set modules electronic control and/or control limiter at desired setpoints.

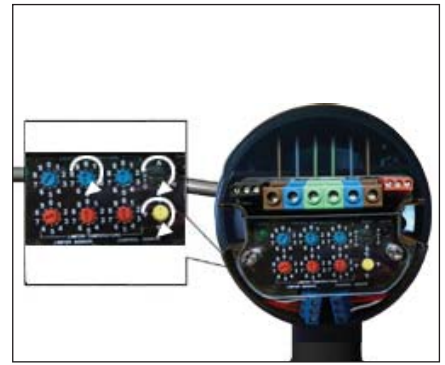

11. Use the rotary switches for settling Control and Limit Temperature, (Celsius or Fahrenheit) and Auto or Manual reset (Control switches on Type "C", Limiter switches on Type "L" and both on Type "CL").



12. Install junction box lid and twist hand tight. Insert screwdriver into ratchet slots located on side of junction box base. Use screwdriver to ratchet on junction box lid. Lid will rotate 30 degrees. To remove lid, repeat steps in the opposite direction.

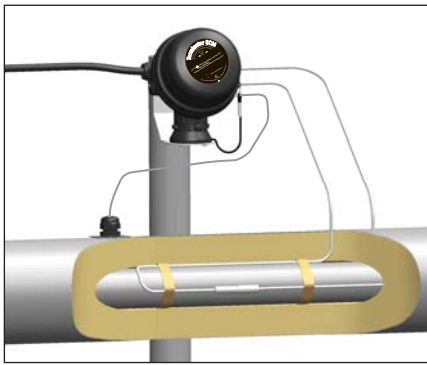

13. Fix PT100 to pipe. Seal penetration through insulation cladding.

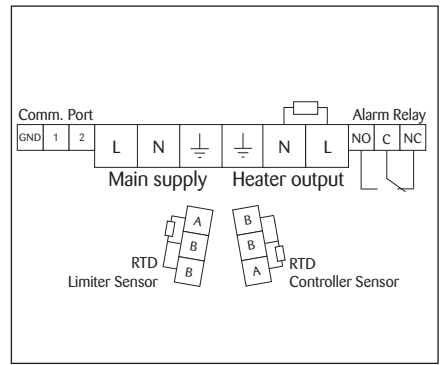

Wiring Details



THERMON . . . The Heat Tracing Specialists®
www.thermon.com

European Headquarters
Boezemweg 25 • PO Box 205
2640 AE Pijnacker • The Netherlands
Phone: +31 (0) 15-36 15 370

Corporate Headquarters
100 Thermon Dr. • PO Box 609
San Marcos, TX 78667-0609 • USA
Phone: +1 512-396-5801

For the Thermon office nearest you
visit us at . . .
www.thermon.com



Specifications and information are subject to change without notice. Form PN50870U-0113